

**International Journal of Engineering  
Research and Sustainable Technologies**  
Volume 1, No.1, September 2023, P 21 - 30

ISSN: 2584-1394

---

**TRIPLE APPROACH SOLUTION FOR DISTRIBUTION FEEDER LOSS  
MINIMIZATION**

M Madhusudhana Raju\*<sup>a</sup>, M.Vishnu<sup>b</sup>

<sup>a</sup>Chola MS Risk Services, <sup>b</sup>Voltech Excellence Engineering Products and Services, India

\* Corresponding author: madhusudhanaraju@cholams.murugappa.com

<https://doi.org/000000/000000/>

---

**Abstract**

The contribution of this work is presented in three stages. The restructuring problem for the distribution network will be considered as the initial stage of work. In this work the restructured Distribution feeder is analyzed using ETAP, which results loss minimization with good tail end regulation. The restructured feeder is implemented practically to achieve quality results. The second stage of the loss minimization works through the energy audit recommendation and incorporation of DG into the distribution system. The sensitivity analysis has been performed to determine the appropriate size and the operating point of DG. The implementation is tested to IEEE and TNEB Distribution feeder using ETAP. The third stage of work is to minimize the line loss and voltage regulation through HVDS concepts. In this work, a study has been carried out in TNEB system using ETAP software. An algorithm was used to convert LVDS to HVDS structure indicating the capacity of small transformer and their locations. It resulted with 10 to 30 % loss minimization with the implementation of all the proposed recommendation

Keywords: Distribution System, Distributed Generation, Energy Audit and Loss Minimization

---

**1. Introduction**

The operation and design standards for distribution networks have undergone recent modifications as a result of many circumstances. Several key factors contribute to the significance of these elements. These include the imperative to conserve energy and employ resources judiciously, the presence of dependable measurement and control apparatus, the heightened expectation from consumers for superior service quality, the deregulation of the electrical energy market, and the emergence of novel systems for monitoring and controlling networks as a result of evolving relationships between generation, distribution, and end-users. The proliferation of novel technologies is becoming increasingly prevalent inside distribution systems. These factors can be effectively addressed by incorporating these elements. Currently, numerous systems have been automated, enabling the centralised or distributed control of various components, including tie-switches, shunt capacitor banks, and under load tap changers. The losses in a power system can be classified into two distinct categories: technical losses and non-technical losses. The primary focus of research in electrical power distribution systems pertains to the examination of technical losses, which constitute a significant proportion of overall losses. The losses that occur naturally, referred to as technical losses, mostly arise from power dissipation in various components of the electrical system, including transmission lines, power transformers, and measuring devices. The computation and control of technical losses can be achieved if the power system under consideration comprises well-defined quantities of loads. This study addresses the issue of achieving optimal centralised control of the aforementioned components in order to improve service quality, namely by flattening the voltage profile and minimising power loss. Loss minimization in power system distribution is a crucial aspect for improving the efficiency and reliability of electrical power systems. Various strategies have been proposed to address this issue. One approach is the placement of Distributed Generation (DG) systems, which can minimize power losses in radial distribution systems [1]. Another method is network reconfiguration, which involves optimizing the distribution network to reduce power loss and improve voltage profiles [2]. Additionally, adjusting tap settings of distribution transformers using optimization algorithms such as Particle Swarm Optimization (PSO) can also minimize losses [3]. Furthermore, the integration of parallel-connected distributed energy storage systems (DESSs) in DC microgrids can mitigate power losses through distributed integral convex optimization control (DICOC) and distributed proportional integral observer (DPIO)-based secondary control [4]. Finally, the placement of DG systems considering reactive power loss minimization can enhance voltage profiles, stability, and reduce active power losses in the distribution system [5]. The static and dynamic effects of placing capacitor banks on busbars of a 20 kV system in distribution systems were analyzed using measurements and tests performed before and after the installation of capacitor banks [6]. Using a hybrid solution (HS) of Particle Swarm Optimization (PSO and GA) to identify and size shunt capacitors for real-time power loss reduction on an 11-kV distribution feeder [7]. A heuristic approach namely Particle Swarm Optimization (PSO) is used for sizing and placement of DGs and the genetic algorithm was used for the placement of the battery energy storage system in the standard IEEE networks such as IEEE-33, IEEE-69 and IEEE-118 radial node distribution systems [8]. Comparative analysis of various methodologies for loss reduction in an electrical power system and present reconfiguration techniques simultaneous with loss reduction and reliability too is given [9]. In this paper, the alternating current optimal power flow (ACOPF) problem is proposed to optimize the transmission loss taking into account system operating limits, which is a nonlinear and nonconvex problem, so

the ACOFP is computationally intractable in practice [10]. The possible ways of reducing technical losses are Network Restructuring, Network Reconfiguration, Incorporating DG into the system, Proper Capacitor Placement, Network Redesign uses FACTS devices and Implementing HVDS etc.,.

The study on loss minimization in distribution systems was conducted in a three-stage process, encompassing feeder restructuring, integration of distributed generation (DG), and implementation of high voltage distribution systems (HVDS) principles. The commencement of the work involved addressing the issue of reconfiguring the distribution network during regular operation in order to mitigate active losses. This paper examines the analysis of an 11KV feeder utilising ETAP software as a case study, with the aim of facilitating effective planning for restructuring purposes. The implementation of the restructured feeder is carried out in a practical manner in order to attain the desired outcomes. During the subsequent phase of the project, various methodologies are suggested to mitigate power dissipation and enhance voltage stability within a distribution feeder by means of distributed generation (DG) injection at the designated bus. The optimal size and placement of Distributed Generation (DG) are crucial factors in mitigating power losses within Distribution Systems. The injection of Distributed Generation (DG) into the Distribution System has been found to enhance the voltage profile while maintaining an acceptable level of line loss. The proposed solutions have undergone testing on IEEE 37 bus Distribution systems and TNEB 11 KV Distribution feeders. During the third phase of the project, an algorithm is employed to transform Low Voltage Distribution Systems into High Voltage Distribution Systems. This study presents a proposed high voltage distribution system and conducts simulation studies using ETAP Software for both an existing and prospective TNEB feeder. The simulation study on High Voltage Distribution Systems (HVDS) demonstrates that the voltage level at the terminal point experiences an estimated rise of 40 Volts. The subsequent part will address the problem statements accompanied by simulated findings.

## **2. Proposed Methodology**

### *2.1 Feeder Restructuring*

This study examines the voltage regulation issues in 11 KV distribution systems, specifically focusing on the voltage regulation problems occurring from the secondary side of the power transformer (33/11KV) to the secondary side of the distribution transformer. The expected voltage at the feeder head is 10.5 KV, which is the median nominal voltage often measured during the summer peak. The objective of the network research is to evaluate the current state of the network in relation to technical losses, equipment loads (such as Cables, Overhead lines, and Transformers), nodes exhibiting aberrant voltages, and contingency situations. The analysis was conducted using the assumptions outlined in the TNEB Power Engineers Handbook [14]. Reported are the anomalous conditions seen within the system, including instances of overloaded equipment and nodes experiencing under voltage. No instances of overvoltage were detected within the network, as the investigation was specifically done under summer peak conditions. In the context of recommending the augmentation of a new distribution transformer, the load is allocated proportionally depending on the rating among all distribution transformers present at a sub-station. This allocation occurs whenever the suggestion is made to add or replace an existing transformer. Suggested enhancements encompass the incorporation of additional feeds, establishment of fresh connectors, or resizing of conductors.

Proposals for the implementation of new feeders have been put forth with the aim of alleviating the burden on multiple existing overcrowded feeders. Additionally, contingency planning has been undertaken to ensure compliance with the N-1 requirement, which involves establishing redundancy within the system, and to minimise the duration of outages. The anticipated result of implementing the N-1 Plan is the establishment of a path with minimal loss and a reduced number of switching occurrences. The identification of potential sites for new feeders is facilitated through the utilisation of Geographic Information System (GIS) data. This data can prove crucial in determining the most suitable locations for establishing new grid stations, which will be necessary to meet future electricity demands. ETAP, a software tool, has been utilised for the aim of doing network analysis on distribution networks.

With the recommendation from the TNEB the existing feeders were simulated in ETAP with an 80% hike in the predicted load for the period of 5 years. The existing feeders are analyzed in ETAP power system software for an improvement in voltage regulation, minimum overload trip time and reduction in line losses. The existing 3 feeders are restructured to 5 new 11KV feeders. The 11KV Industrial estate feeders I with 230 meters of laying of 11KV, 3x300 Sq mm cable from substation breaker. The next feeder is Industrial estate 11KV feeder II with 150 meters of laying of 11KV, 3x300 Sq mm cable from substation breaker. The 11KV JJR Nagar feeder planned with the long of 550 meters. The 11KV KVSA Colony feeder of 150 meters length from substation to Sharma Nagar. The final feeder of length 550meter from SS to Ambetkhar Nagar with

3x300 Sq mm cable is 11KV Vyasarnagar feeder. The proposed scheme is shown in Figure 1, which represents how the feeder got restructured. The performance analysis of the proposed feeder was done in ETAP.

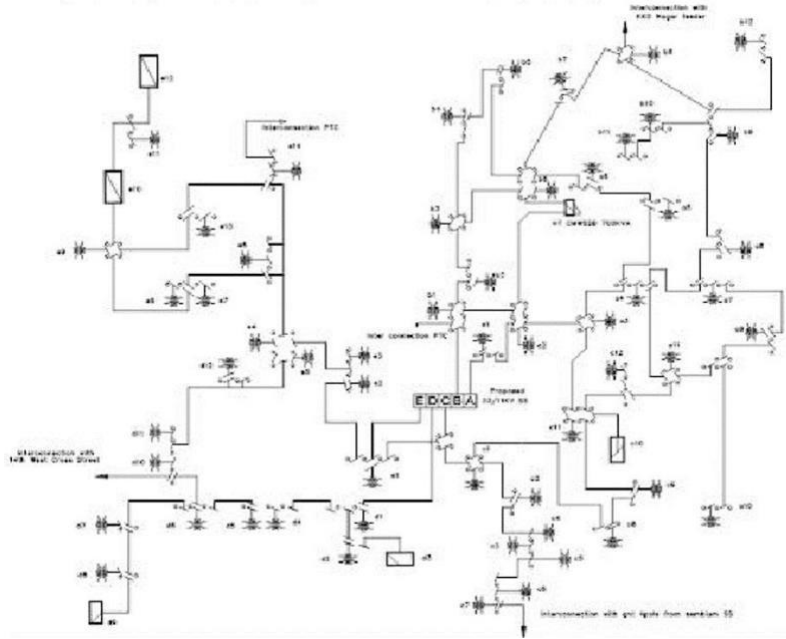

Fig. 1: Schematic Layout of Proposed Systems

## 2.2 Impact during Power Audit and DG

Distribution systems refer to the networks and processes that are utilised to transport goods and services from producers to consumers. These systems play a crucial role in power distribution. Power losses [11-14] exhibit variability due to a multitude of elements contingent upon the system's structure. These factors encompass the extent of losses incurred through transmission and distribution feeders, transformers, capacitors, insulators, and other relevant components. There are two distinct categories of power losses, namely real power loss and reactive power loss. The dissipation of real power is attributed to the resistance of transmission lines, but the generation of reactive power loss is a consequence of the presence of reactive elements. The issue of power loss in utility systems has garnered significant attention due to its impact on the efficiency of energy transmission to customers. It is worth noting that reactive power loss should not be overlooked, as it holds equal significance. The maintenance of a specific level of reactive power flow in the system is necessary in order to provide an adequate voltage level. As a result, the presence of reactive power enables the efficient transmission and distribution of real power to end-users via transmission and distribution lines.

The Sensitivity Analysis is an investigative research that examines the response of the mathematical equation governing an established network when Distributed Generation is introduced. By differentiating with regard to the amount of DG current and rearranging, the change in power losses with respect to the phase angle of DG current may be obtained. This can be achieved by differentiating the power losses with respect to DG, resulting in a sensitivity analysis. The sensitivity indices provided can be utilised for doing sensitivity analysis on real and reactive power losses. These indices serve to illustrate the variations in power losses in relation to distributed generation (DG). As per the TNEB's advice, the existing feeders were simulated in ETAP software, incorporating an 80% increase in the projected load.

$$\begin{bmatrix} \Delta P_{Loss}^{DG} \\ \Delta Q_{Loss}^{DG} \end{bmatrix} = \begin{bmatrix} \frac{\partial P_{Loss}^{DG}}{\partial |I_{DG}|} & \frac{\partial P_{Loss}^{DG}}{\partial \theta_{DG}} \\ \frac{\partial Q_{Loss}^{DG}}{\partial |I_{DG}|} & \frac{\partial Q_{Loss}^{DG}}{\partial \theta_{DG}} \end{bmatrix} \begin{bmatrix} \Delta |I_{DG}| \\ \Delta \theta_{DG} \end{bmatrix}$$

Only if the real power loss reaches zero does it attain its minimum value. With a DG system connected to a bus in a distribution system, it is possible to calculate the DG's maximum current injection for minimum actual power loss. Likewise,

reactive power loss achieves its minimum value only when it reaches zero. With a DG connected to a bus in the distribution system, it is possible to calculate the utmost current injection by the DG system for minimum reactive power loss. Using the above sensitivity matrix and constant impedance load model, the optimal location of the DG for minimising loss can be determined.

### 2.3 HVDC Concepts

This paper proposes the reorganisation of the Low Voltage Distribution System (LVDS) by extending the 11 kV high-voltage line to the final consumer using HVDS concepts. The ancient, high-capacity transformers were replaced with new, smaller-capacity transformers to accommodate the specified loads. The algorithm identifies the location and quantity of transformers required for HVDS restructuring. The proposed HVDS TNEB layout is simulated in ETAP [15] using existing TNEB data and the TNEB Power Engineers Handbook [14] to accomplish the desired results.

The existing distribution system taken for analysis is from TNEB Kovur-Substation. The Kovur-Substation is 20 km from Chennai city and it has three feeders Kovur, Mancherry and Kundrathur. These feeders are loaded with domestic, motor and industrial loads. Among these feeders 11KV Mancheery feeder of 33/11KV Kovur-SS is taken for analysis. There are 26 DTRs (Distribution Transformers) spread across the area of about 6 km. From the 26 DTRs of the Mancherry feeder four DTR's LVDS are taken for restructuring. They are: Mundramkattalai 250 kVA DTR, Thandalam -I 250 kVA DTR, Thandalam-II 250 kVA DTR and Reddairtheru nagar 250 kVA DTR

The ETAP layout of an exist LVDS system of Thandalam-II with 250 kVA is shown in Figure 2. In this network the load is distributed along the LT line and in some buses a large number of loads are given. It has four feeders connected to the transformer in which two feeders are with minimum length. The voltage magnitude is 87.5% at the tail end consumers of the lengthy feeder. This feeder also faces a poor voltage regulation problem. The lengths of the feeders are 1 and 1.5 km respectively.

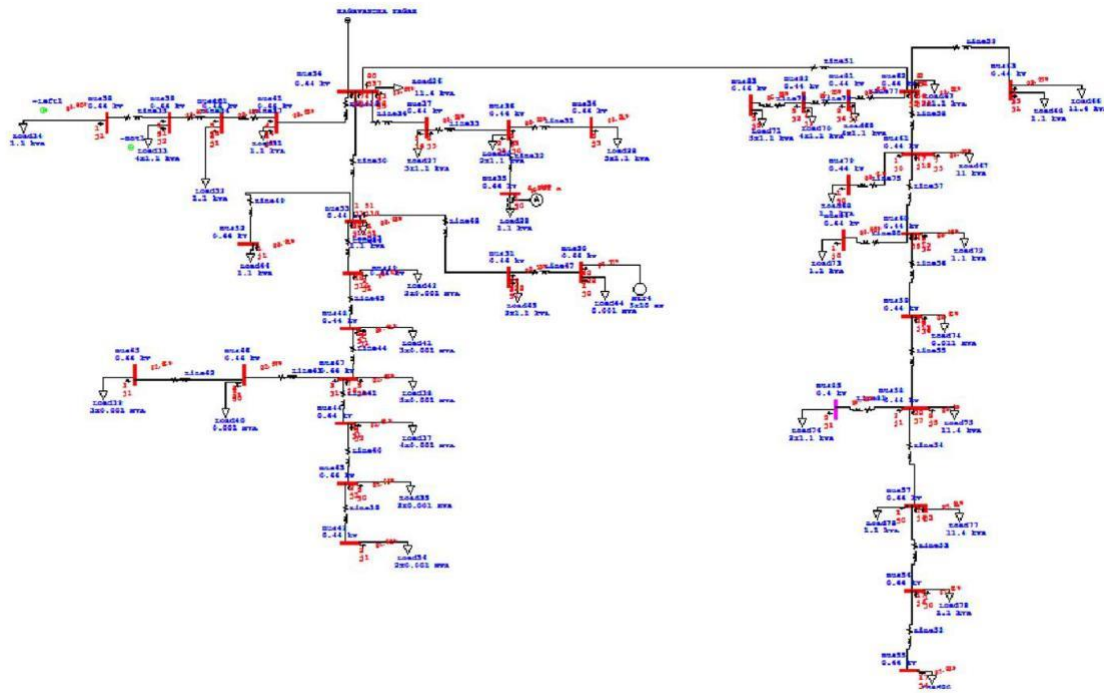

Fig. 2: ETAP Simulated -LVDS system of Thandalam-II 250 KVA

The LVDS feeders are converted to HVDS feeders through an optimization algorithm. This algorithm is to identify the total number of small capacity transformers needed for HVDS conversion and the location of transformers to obtain minimum line losses with quality power. The conversion process was undertaken using a Particle Swarm Optimization Algorithm [16] [17]. The steps involved in the algorithm are discussed below.

Step 1: Get LVDS input line, bus and load data.

Step 2: Initialize particle size and velocity.

Step 3: Initialize the random location of the transformer.

Step 4: If satisfied with feeder length & total loads, allocate the capacity of transformers. Go to step 5, else go to step 2.

Step 5: Select next location of transformer, go to step 4.

Step 6: If all feeders get analyzed, print the exact location of the transformer to be placed.

Step 7: Stop.

Here, the simulated network of the restructured HVDS system of Thandalam-II 250 kVA DTR is given in Figure 3. This was done by 7 small DTRs of rating 10, 20, 25, 30, 50 kVA based on the load. The HT line here was also extended and the LT line was reduced and in some places replaced by ABC (Aerial Bunch Cable) to minimize the theft or hooking of illegal connections in the networks. The tail end voltage magnitude in the network is 87%.

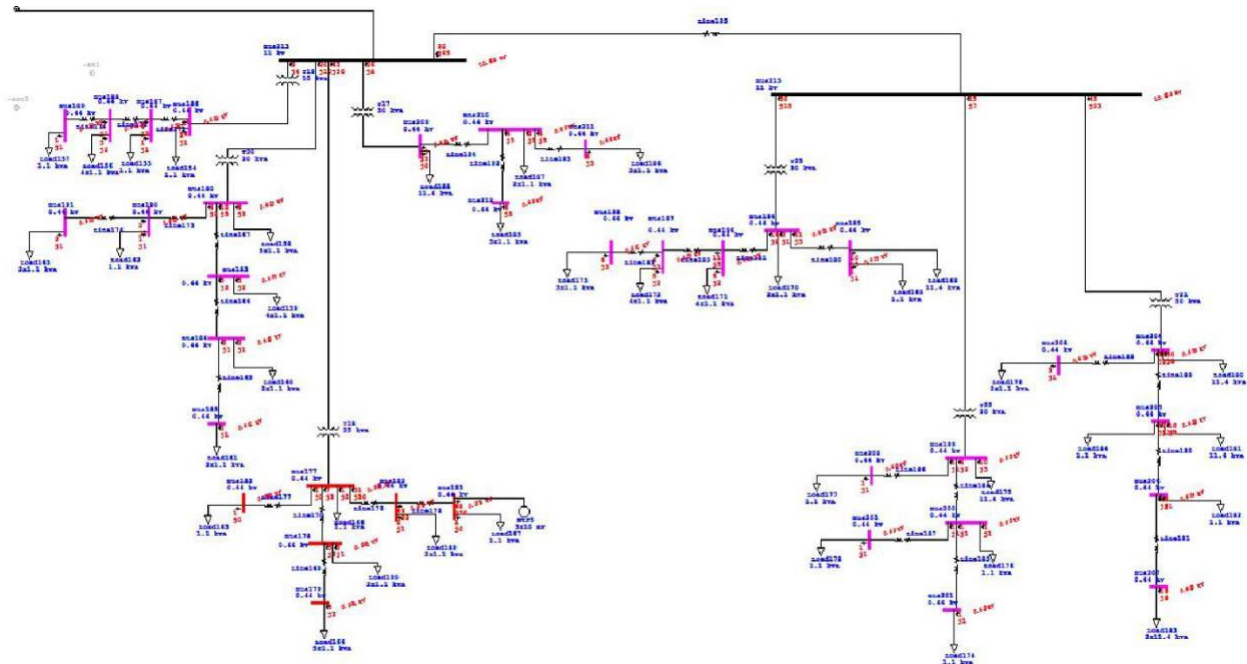

Fig. 3: Restructured Thandalam II HVDS feeder

### 3 Case Study Results and Discussions

#### 3.1 Feeder Restructuring

In order to address the aforementioned problems with the existing feeders, the substation feeder was reconfigured and the three output feeders were substituted with five feeders. ETAP [15] was used to simulate the modified system for performance

analysis. The system's overall efficacy has increased. The identified issues with overheating, voltage regulation, and line loss have been resolved. The substation has two 33kV input feeders, one of which is the primary feeder and the other the backup feeder. The HV supply is derived from the primary Vyasarpadi UG feeder, and the Sembium feeder is a backup feeder that is only used when the primary feeder is down for some reason, so that the supply can continue to flow to the customers. Five proposed output feeders are designated as S.A. Colony, Vyasarnagar, JJR Quarters, Industrial Estate-I, and Industrial Estate-II.

The proposed new feeder with new substation was recommended to TNEB. TNEB implemented the proposed scheme in the Vyasarpadi substation in the year 2008. After practical execution of the project work the revised line loss and voltage regulation in each feeder is expressed in Table 4.9 – Table 4.12. The regulations of the implemented feeders were observed to be maintained in between 0.5 to 1.63%, which is given in Table 1. The connected load capacity and the expected maximum demand of the proposed five feeders are within the rated capacity of the feeders. The Industrial Estate II feeder regulation is found to be 1.6%, due to the maximum load connected to it.

**Table 1**  
Proposed Feeder Regulations

Sl.No	Name of the feeder	Connected Load (KVA)	Diversity Factor	Expected Max.Dem. (KVA)	Proposed Regulation (%)
1	Vyasarnagar	3700	1.67	2215.57	0.75
2	JJR Nagar	3250	1.89	1719.58	1.02
3	SA Colony	4000	1.67	2395.21	0.50
4	Industrial Estate I	4750	1.84	2581.52	0.50
5	Industrial Estate II	6500	1.84	3532.61	1.63
Total				12444.49	0.75

The existing 11KV Vyasarpadi feeder was proposed to S.A.Colony, Vyasarnagar and Vyasarpadi feeders. The Table 2 shows that a total loss of 39407 units/month was measured for the existing feeder and the total of 14039 units/month was measured for the proposed feeders. The line loss savings is observed to be 25368 units/month.

**Table 2**  
Vyasarpadi feeder – Line Loss Saving

Name of the feeder	Existing Regulation	Existing Loss%	Proposed Regulation	Proposed Loss %	Existing Loss(units)	Proposed Loss(units)
	A	B	C	D	E	F=(ExD)/B
Vyasarpadi	5.67	1.898			39407	
Vyasarpadi			0.17	0.17		3475
SA Colony			0.55	0.55		7089
Vyasarnagar			0.17	0.17		3475
Total					39407	14039
Line Loss Savings						25368

The MKB Nagar existing feeder measured line loss is 27387units/month. The proposed JJ Nagar and M.K.B Nagar feeder losses in units/month are measured as 13389. It is clear from the Table 3 that the line loss savings/month is 13998unit/month . All these data was provided by TNEB office.

**Table 3**  
M.K.B Nagar – Feeder Loss Comparison

Name of the feeder	Existing Regulation	Existing Loss%	Proposed Regulation	Proposed Loss %	Existing Loss(units)	Proposed Loss(units)
	A	B	C	D	E	F=(ExD)/B
MKB Nagar	5.3.6	1.898			27387	
MKB Nagar			0.74	0.39		5630
JJR Nagar			1.02	0.54		7760
Total					27387	13389
Line Loss Savings						13998

The Table 4 gives the overview of the existing and proposed feeder line loss savings in unit/month for Industrial Estate feeder. The line loss savings in the Industrial Estate feeder are found to be 25412 units/month. These data help us to check the energy loss saving and the respective cost analysis calculations later.

**Table 4**  
Industrial Estate Feeder - Line loss comparisons

Name of the feeder	Existing Regulation	Existing Loss%	Proposed Regulation	Proposed Loss %	Existing Loss(units)	Proposed Loss(units)
	A	B	C	D	E	F=(ExD)/B
Industrial Estate Exg	7.68	2.18			39973	
Industrial Estate Exg			0.50	0.14		2602
Industrial Estate I			1.63	0.46		8484
Industrial Estate II			0.50	0.17		3475
Total					39973	14561
Line Loss Savings						25412

Due to overloading in the existing feeders, it was observed that frequent overload tripping occurred in all feeders which is expressed in Table 5. It was anticipated that after the proposed completion of the project, there is no possibility of tripping due to overload.

**Table 5**  
Assessment of Power Outage in Existing Feeders

Sl.No	Name of the feeder	Average unit consumption per month	Average interruption per month	Losses in units C=(AxB)/720
		A	B	C
1	Vyasarjadi	1624957	3.01	6793
2	MKB Nagar	1442500	2.05	4107
3	Industrial Estate	1825667	2.25	5705
	Total Unit			16606

The per month total savings of unit's is 81384. The total investment for the new proposed feeders is 28 lakhs. The payback period is found to be 10.67 years.

### 3.2 Audit with DG Implementation

The test system utilised in this study is derived from the 11KV distribution feeder of the Tamil Nadu Electricity Board (TNEB). The single line diagram of the test feeder, as depicted in Figure 4, is generated using the ETAP software. The objective of this study is to minimise losses by proposing power audit recommendations and implementing distributed generation (DG) techniques. The initial power audit commenced the process of gathering all necessary data from a total of 95 residential dwellings. The system under consideration is a radial feeder consisting of 24 buses, which are interconnected with both three-phase and single-phase power supply. The length of the feeder is one kilometre. Recommendations are categorised into many domains, including investment, advantages, and quality. The investment is categorised into three tiers: minimal investment, medium investment, and maximum investment. The benefits can be categorised into two groups: minimum benefits recommendation and maximum benefits recommendation. The suggestion quality is categorised into high and low quality. A comprehensive analysis was done to provide thorough recommendations for all 95 properties, including a comparison of unit savings.

The authors have advised the use of distributed generation (DG) systems, including solar panels and wind mills, for buses based on the algorithm's recommendations derived from sensitivity analysis. The investigation of the size and location of distributed generation (DG) is conducted through sensitivity analysis. In order to assess the effectiveness of the suggested methodology, experiments were conducted on the 11kV Distribution feeder of the Tamilnadu State Electricity Board. The examination of test systems is conducted using the ETAP Power System Software Package.



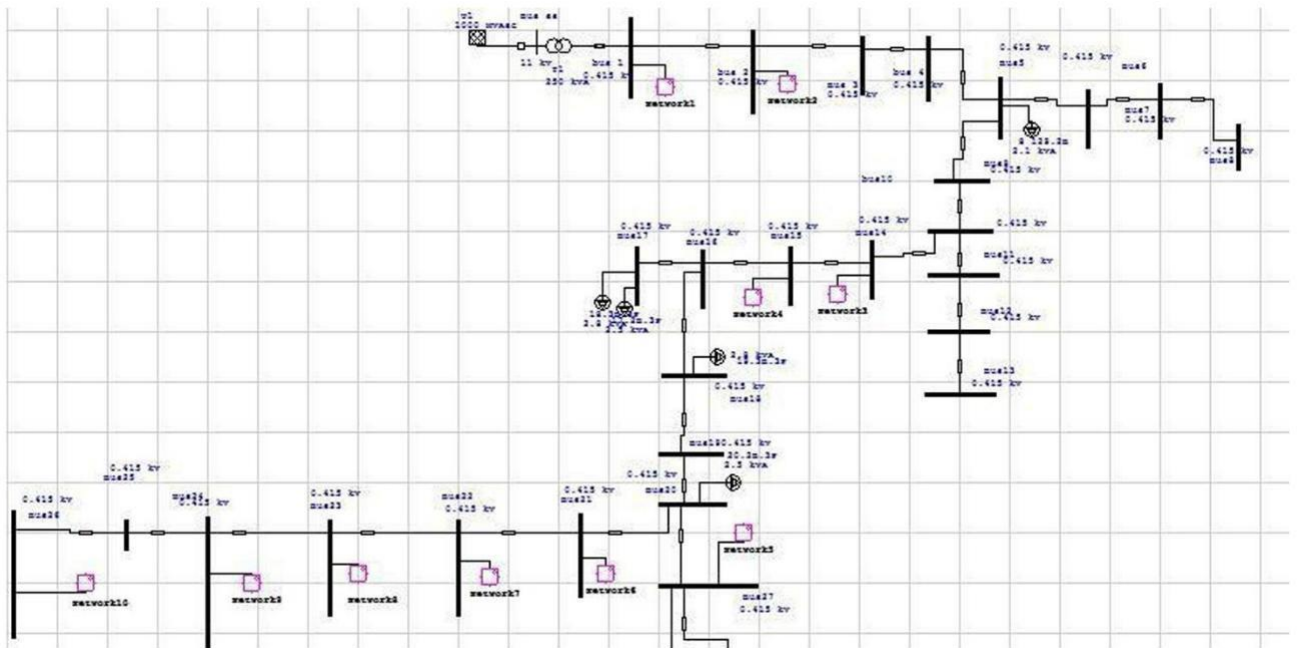

**Fig. 4:** TNEB test Feeder

Based on the obtained sensitivity indices, it is determined that the placement of DG occurs at bus numbers 5, 17, 20, and 25. The allocation of the 56 photovoltaic (PV) panels is determined based on the limitations imposed by the available installation space and the approval received from customers for rooftop placement. Four potential sites have been found for the installation of solar panels, while two spots have been identified for the erection of wind turbines.

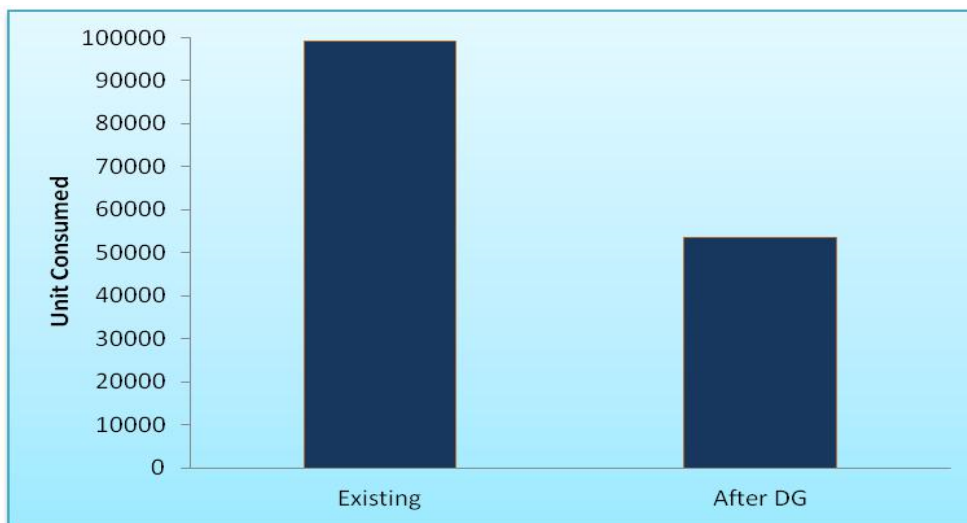

**Fig. 5:** Unit Saved after and before implementation of DG

The figure 5 represents the unit consumed in the existing system and the unit consumed after implementation of DG. The unit saved under full operation of DG is 45468. The calculated percentage of unit savings is 39%. The resulted distribution loss before the implementation of DG is 33 % and 15% after the implementation of DG. This work will help the electricity board to take decision on minimization of loss with the acceptable voltage profile.



### 3.3 HVDS Tested Output

The existing and proposed systems were analyzed with the help of ETAP software [15]. The limitations of low voltage distribution systems (existing system) were rectified very well by its restructuring to a high voltage distribution system. The power factor was found to be improved and tail end voltage was also improved. The losses due to the failure of DTRs due to heavy loads were also reduced. As the high voltage lines were extended as close to the loads as possible, the possibilities of unauthorized connection were reduced. These consequences were justified by the graphs obtained from the simulation of the restructured system when compared to the simulation graph of the existing system. The percentage voltage magnitude, real power, reactive power and line losses were compared to the existing and proposed systems.

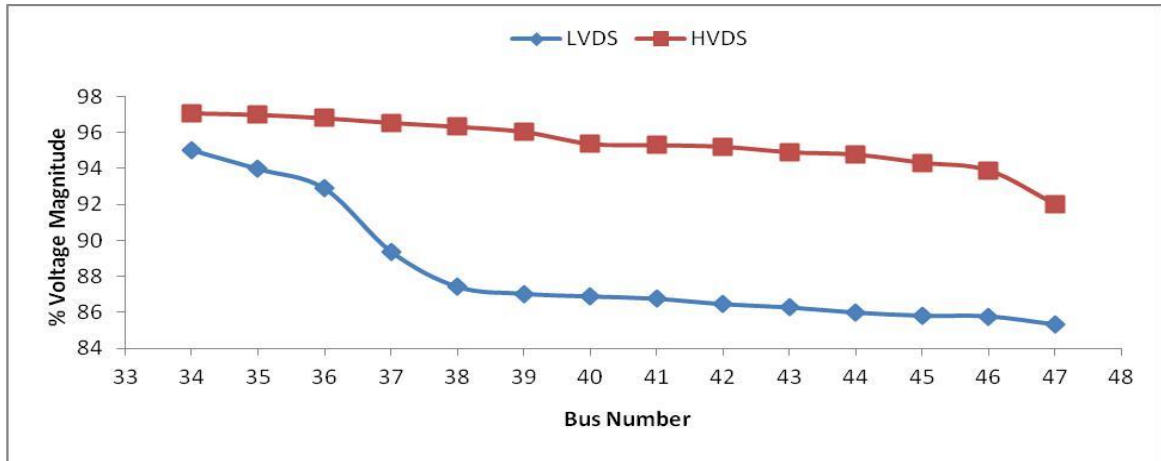

Fig. 6: LVDS and HVDS Comparison of Thandalam- II Feeder

The voltage magnitude percentage output of Thandalam-II feeder with the simulated results of LVDS and HVDS is shown in figure 6. The LVDS simulated voltage magnitude has a large variation from 95 to 83%. The measured LVDS line loss was 16.82%. The limitations were rectified and improved by the proposed HVDS feeder. From the starting at the tail end, there was a gradual increase and decrease in voltage, but it was maintained in between 94 and 97%. The measured line losses of 5.3 % are acceptable for quality power flow.

From the ETAP simulated text report of all the case studies, the comparison of the four feeders for LVDS and HVDS percentage line losses is shown in figure 7. The LVDS simulated percentage line loss was maintained in between 13 to 18%. However the acceptable line loss was  $\pm 5$  %. The LVDS feeder line losses were not within acceptable limits. This will therefore increase the cost of the generation. The proposed HVDS feeder line loss was in the acceptable limit range between 3 - 5.5%.

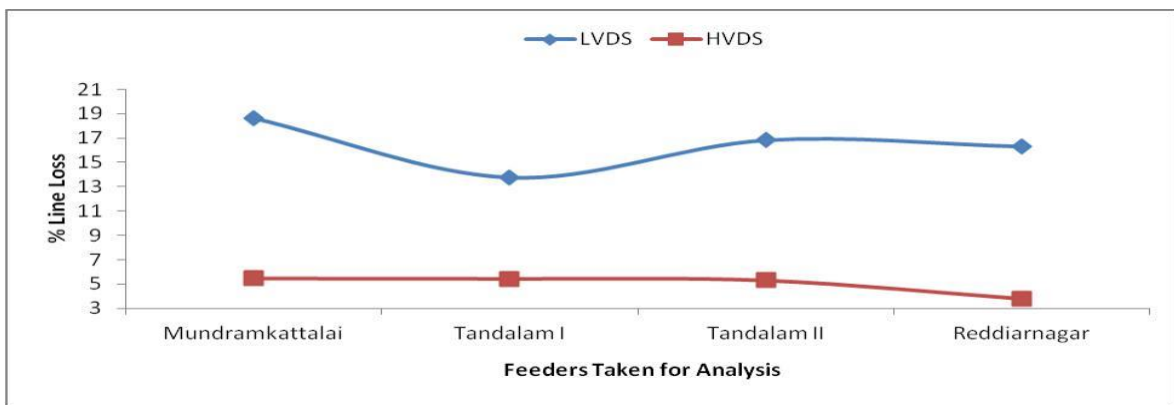

Fig. 7: LVDS and HVDS Comparison of % Line Loss

#### 4 Case Study Results and Discussions

The initial phase of the project involved the implementation of appropriate restructuring measures to reduce line loss in electrical power distribution system feeders. The investigation revealed that the average percentage voltage regulations for the planned and existing feeders were 0.88% and 5.6%, respectively. The subsequent phase of this study elucidates the interplay between distributed generators (DGs) and distribution networks. The findings from multiple experiments conducted using ETAP software demonstrated that the integration of distributed generation (DG) into the distribution system yielded significant benefits in terms of lowering power losses within the distribution networks and enhancing the regulation of load voltage. The subsequent phase of the project involved the implementation of HVDS ideas in order to reduce line loss and voltage regulation in electrical power distribution system feeders. The simulation results have confirmed that the High Voltage Distribution System (HVDS) has technical superiority over the standard Low Voltage Distribution System (LVDS) in terms of supply quality. This superiority is characterised by a more favourable voltage profile, decreased losses, and enhanced dependability. When considering the comprehensive cost and benefit analysis of the system, it can be concluded that HVDS demonstrates greater economic advantages and benefits in comparison to LVDS. The observed tail end voltage in the existing system was measured at 360 V, while in the proposed system, it was noted to be 420 V based on the simulation results.

#### References

1. Ali, Tarraq., F., El, Mariami., Abdelaziz, Belfqih. (2023). New typical power curves generation approach for accurate renewable distributed generation placement in the radial distribution system. *International Journal of Power Electronics and Drive Systems*, doi: 10.11591/ijece.v13i5.pp4909-4918
2. Ponnusamy, Marimuthu., V., Moorthy., B, Pangedaiah., Ch., Rami, Reddy., Malligunta, Kiran, Kumar., Muhammad, Khalid. (2023). Investigation and Minimization of Power Loss in Radial Distribution Network Using Gray Wolf Optimization. *Energies*, doi: 10.3390/en16124571
3. Chodagam, Srinivas., Isukapalli, Kranthi, Kumar., N., D., V., P., Pandalaneni., Naveen, M., Reddy. (2022). Minimization of Power Loss in Distribution System by Tap Changing Transformer using PSO Algorithm. *International journal of electrical & electronics research*, doi: 10.37391/ijeer.100460
4. Ya, Jie, Jiang., Yun-lei, Yang., Siew-Chong, Tan., Shu, Yuen, Ron, Hui. (2022). Distribution Power Loss Minimization of Energy Storage Systems in DC Microgrids Under FDI Attacks. doi: 10.1109/ECCE50734.2022.9947585
5. Vani, Bhargava., S., K., Sinha. (2022). DG Placement in Distribution System for Voltage Profile Enhancement and Loss Reduction by Reactive Power Loss Minimization. doi: 10.1109/ICCCIS56430.2022.10037608
6. Michal, Kolcun., Zsolt, Conka., Vladimir, Kohan., Róbert, Štefko., Marek, Pavlik., Dost, Mohammad, Sarwari. (2022). Application of Capacitor to Distribution System for Minimization of Power Losses. doi: 10.1109/EPE54603.2022.9814127
7. Egeruo, Sochima, Abraham., I, Ojo, Oluwafemi. (2022). Power loss minimization and voltage profile improvement on electrical power distribution systems using optimal capacitor placement and sizing. *International journal of advances in electrical engineering*, doi: 10.22271/27084574.2022.v3.i1a.14
8. Kamal, Chellappan., Vedula, Sri, Siva, Chaitanya, Satyanarayana, Murty., Narayan, Krishnan., Gulshan, Kumar, Sharma., Tomonobu, Senju. (2022). Real Power Loss Minimization Considering Multiple DGs and Battery in Distribution System. *Electric Power Components and Systems*, doi: 10.1080/15325008.2021.2011488
9. Rajnesh, Kumar, Yadav. (2021). A Comparative analysis of Various Power loss minimization techniques for Distribution Network. *Journal of emerging technologies and innovative research*,
10. Akira, Chuppawa., Sotdhipong, Phichaisawat., Patchrapa, Wongchai. (2021). ACOPF with SOCP Hierarchy for Power Loss Minimization. doi: 10.1109/ECTI-CON51831.2021.9454708
11. Willis, *Power Distribution Planning Reference Book*. New York: Mercel Dekker, Inc., second ed., 2004.
12. Anthony J. Pansini, *Guide to Electrical Power Distribution Systems*, Sixth Edition CRC Press, 2005.
13. T.A. Short, *Electrical Power Distribution System Hand Book*, 2004 by CRC Press LLC.
14. Power Engineers – *Handbook of TNEB*, Chennai, 1989.
15. ETAP - Product Overview – Power System Enterprise Solution, Operation Technology Inc.
16. Yuh and Sung, Report on “Application of the PSO for Transformer Rearrangement”, Department of Electrical Engineering, Fortune Institute of Technology, Taiwan.
17. Gopiya Naik, D. K. Khatod and M. P. Sharma, “Optimal Allocation of Distributed Generation in Distribution System for Loss Reduction”, IACSIT Press Singapore Conferences PCSIT, vol. 28, page 42-46, 2012